





AUSFÜHRUNGEN

FORMS

FORMES

FORMEN

Die Metaldeckenplatte wird immer von oben gesehen. Das ist wichtig bei asymmetrischen Ausführungen und bei der Anwendung von Durchbrüchen.

Längsseitige Aufkantungshöhe, wenn nichts angegeben, nach statischen Erfordernissen.

Rechteck

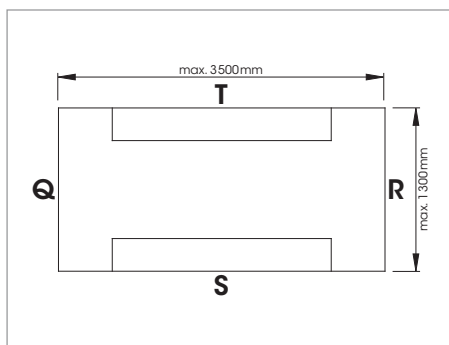

FORMS

In the drawings, metal ceiling panels are always seen from above. That is important for asymmetric versions and where there are apertures.

Where no dimension is given, the flange height on the long side is chosen to meet structural requirements.

Rectangular

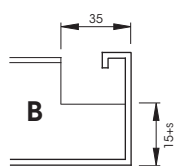

FORMES

Le panneau de plafond métallique est toujours vu de dessus. Cela est important pour les exécutions asymétriques et l'utilisation de passages.

Hauteur de retour côté longueur, sauf autres indications, selon exigences statiques.

Rectangle

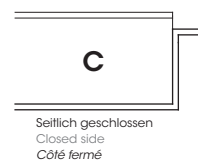

Quadrat

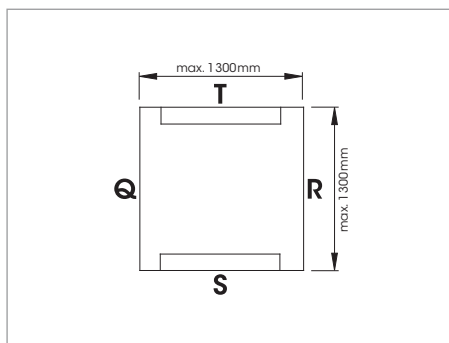

Square

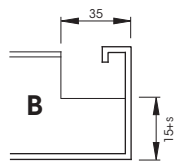

Carré

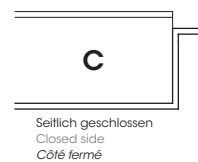

Einseitiges Trapez

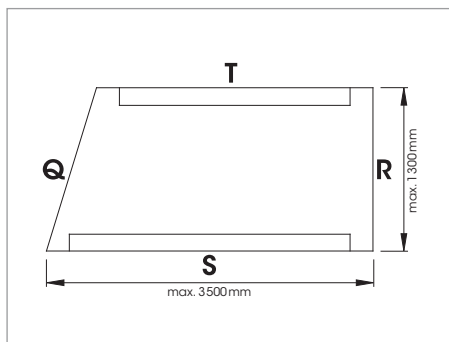

Trapezium, one end

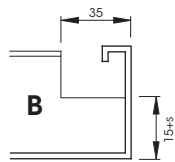

Trapèze rectangle

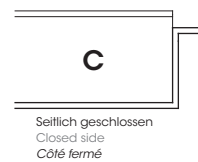

Trapez

Trapezium

Trapèze

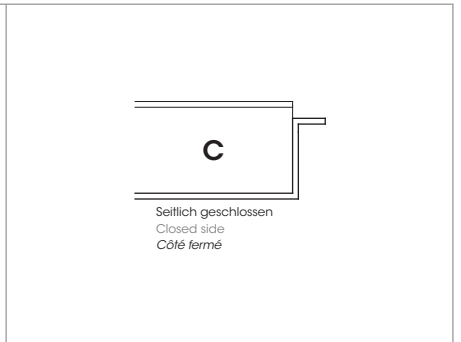
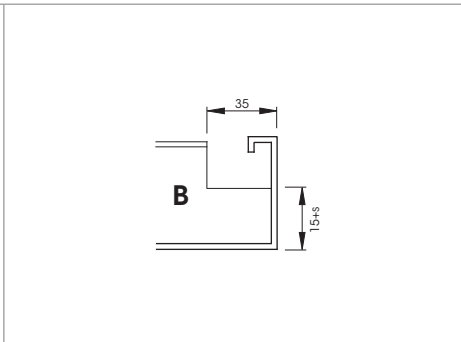
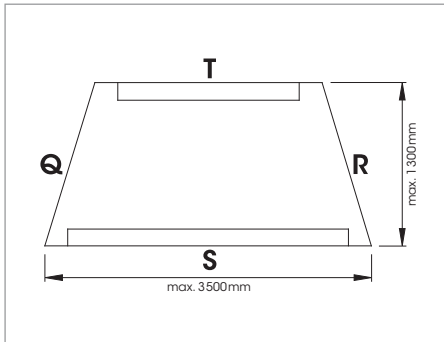

Dreieck

Triangle

Triangle

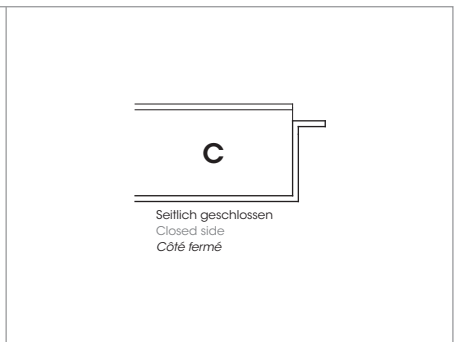
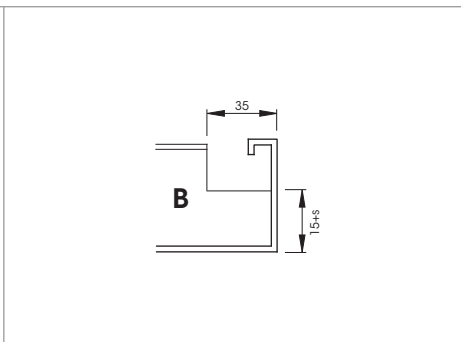
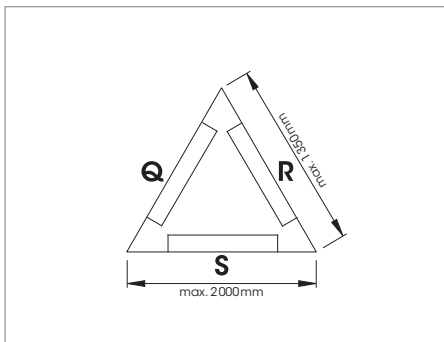

STIRNSEITEN FRONT SIDES COTE LARGEUR

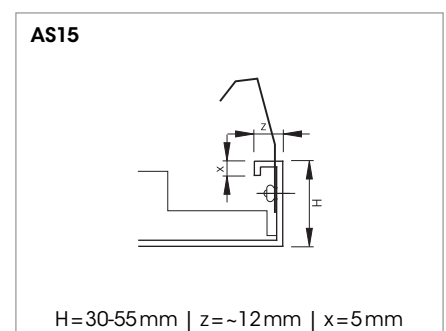
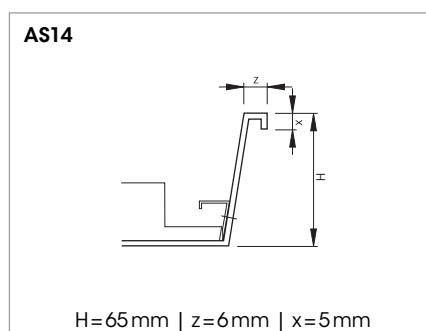
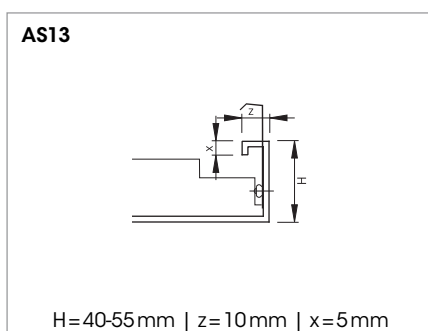
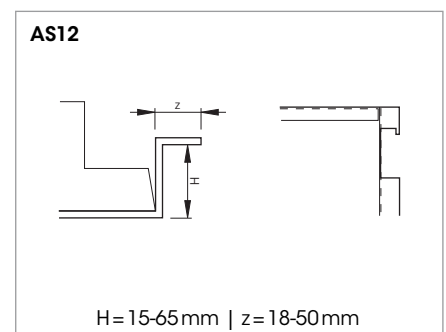
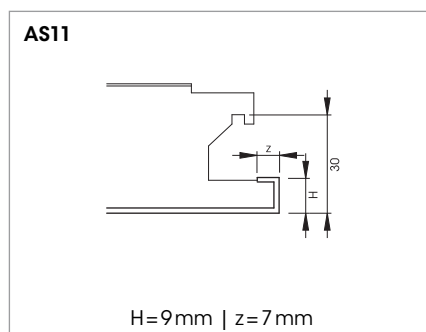
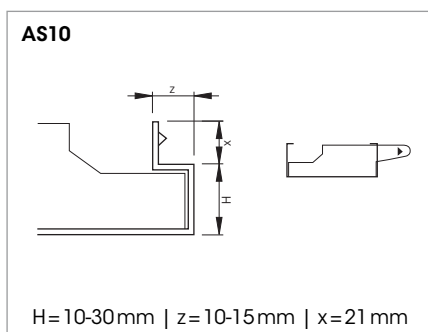
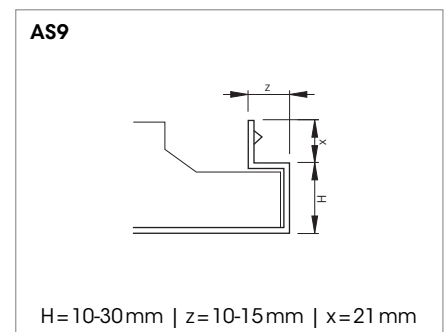
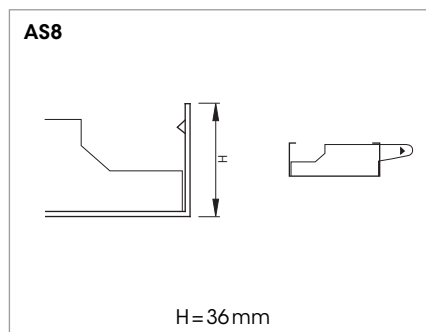
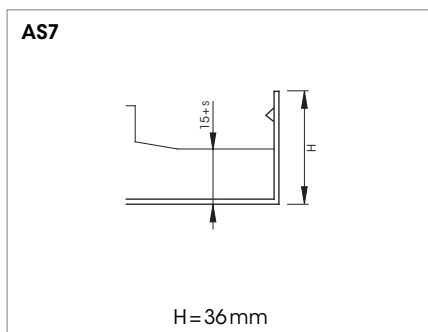
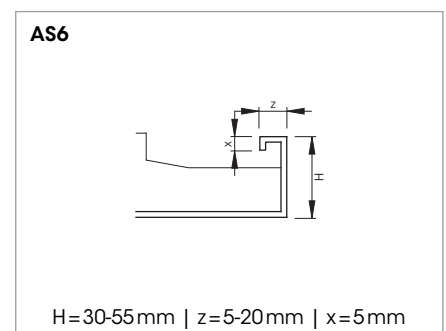
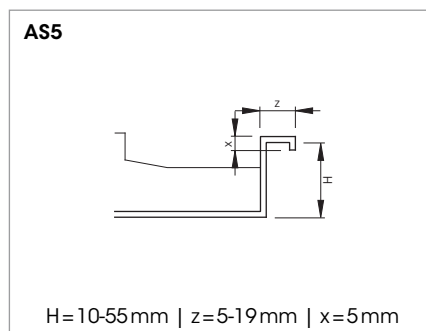
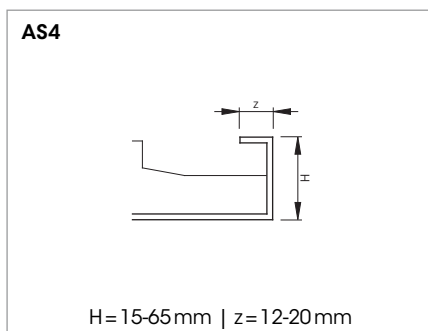
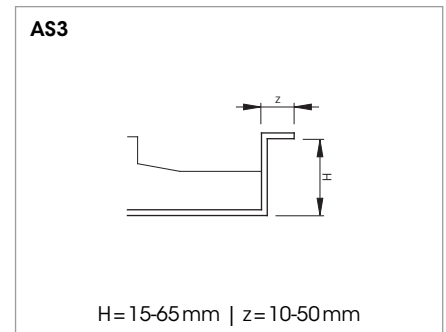
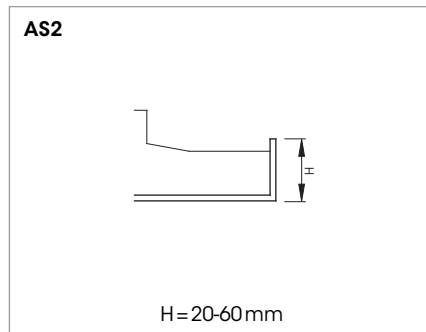
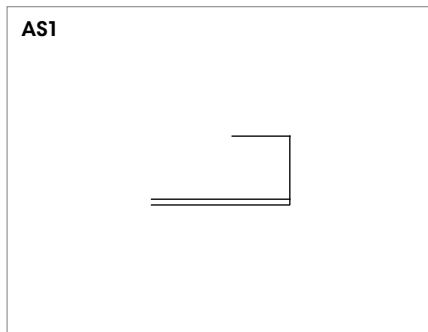

STIRNSEITEN FRONT SIDES COTE LARGEUR

AS16

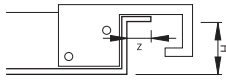

H=30-65mm | z=7-19mm

AS17

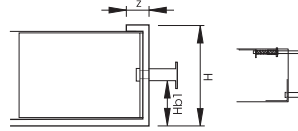

H=30-60mm | z=7-19mm | Hb1=10-50mm

AS18

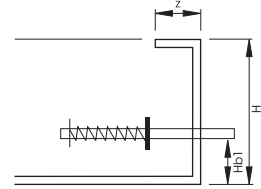

H=30-60mm | z=7-19mm | Hb1=10-50mm

AS19

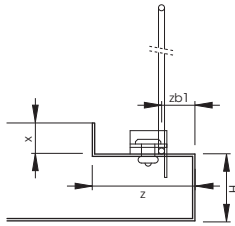

H=17-25mm | z=29mm | x=11-19mm
zb1=10mm

AS 20

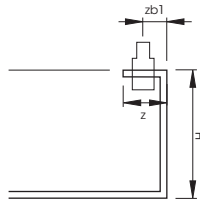

H=30-60mm | z=18-19mm | zb1=9,5mm

AS21

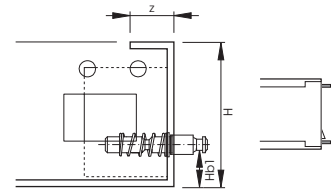

H=40-65mm | z=7-12mm | Hb1=8,5mm

AS22

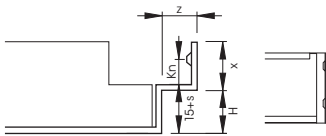

H=15mm | z=10mm
x=17mm | Kn=11,2mm

AS23

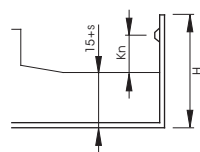

H=32mm | Kn=11,2mm

AS26

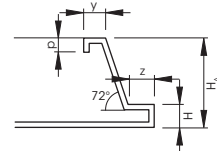

H=12mm | H_A=55mm | z=16mm
y=12mm | p=8mm

AS27

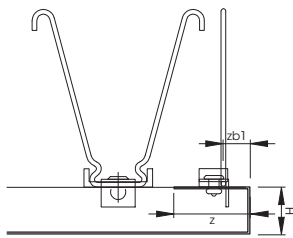

H=17-25mm | z=29mm | zb1=10mm

AS29

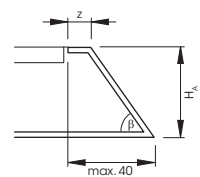

H_A=45-50mm | z=12-20mm | β=50-55°

LÄNGSSEITEN LONG SIDES COTE LONGUEUR

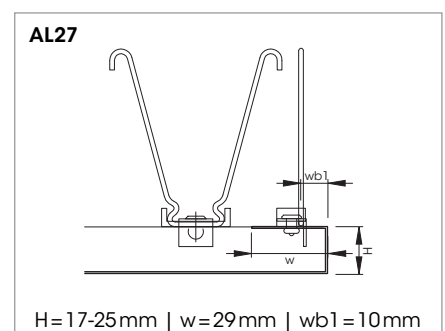
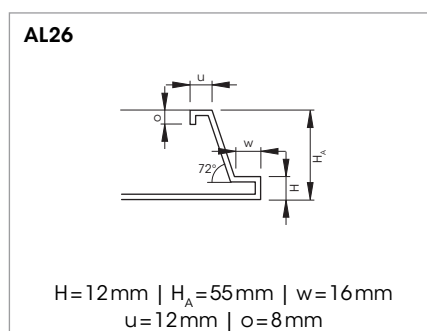
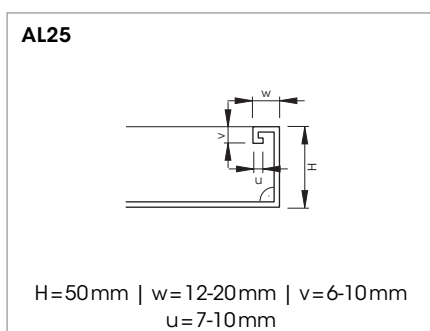
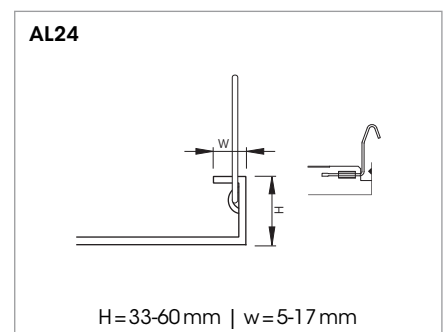
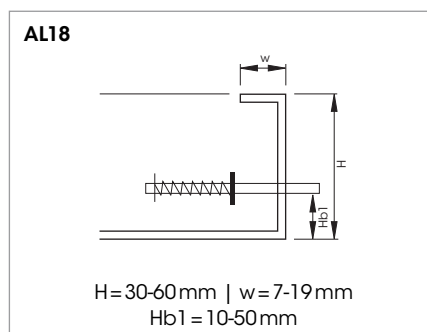
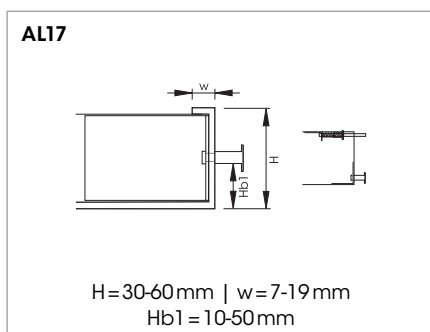
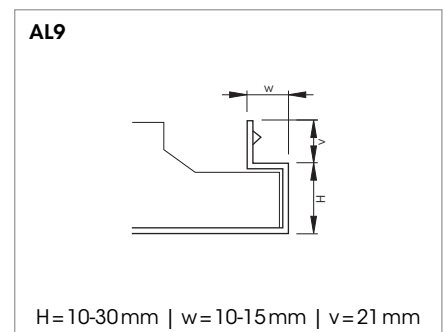
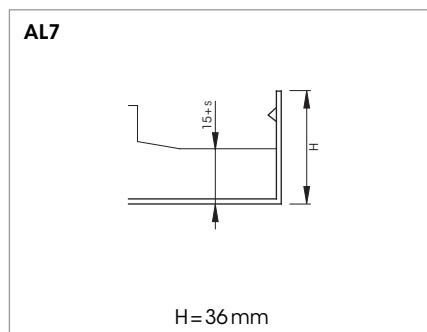
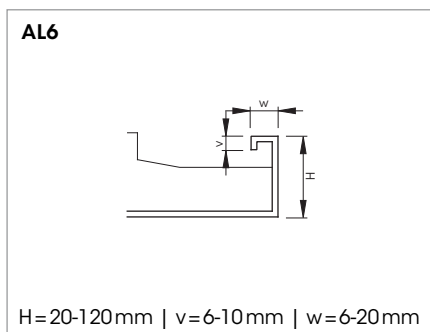
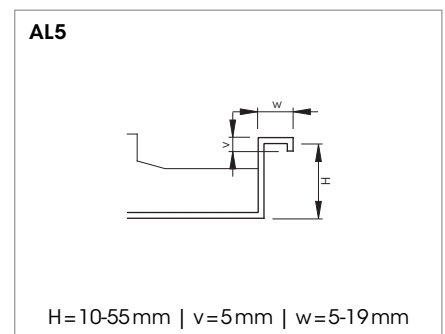
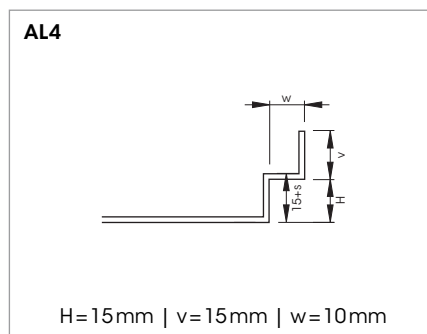
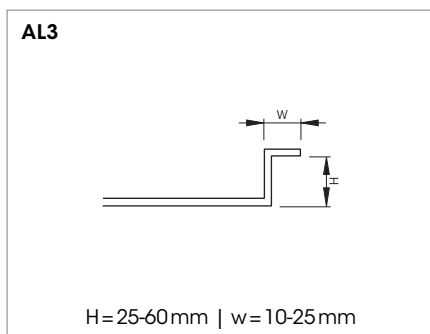
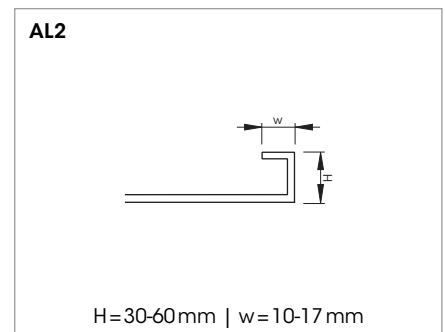
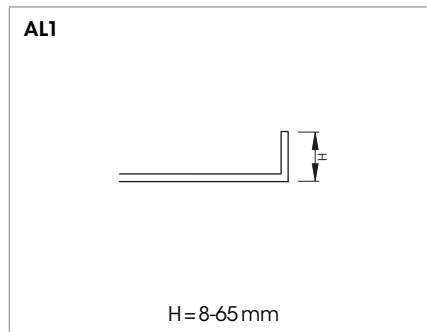
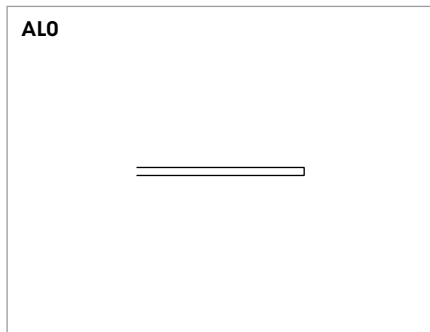

LÄNGSSEITEN LONG SIDES COTE LONGUEUR

AL28

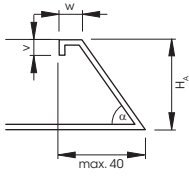

$H_A = 45-50 \text{ mm}$ | $w = 12-20 \text{ mm}$
 $v = 6-9 \text{ mm}$ | $\alpha = 50-55^\circ$